

S.NO	CATALOG NUMBER	D	W
1	BGSBS182620	16.50 [419]	26 [660]
2	BGSBS183020	16.50 [419]	30 [762]
3	BGSBS186020	16.50 [419]	60 [1524]
4	BGSBS223020	20.50 [521]	30 [762]
5	BGSBS223620	20.50 [521]	36 [914]
6	BGSBS166020	14.50 [368]	60 [1524]
7	BGSBS184820	16.50 [419]	48 [1219]
8	BGSBS186020	16.50 [419]	60 [1524]
9	BGSBS222420	20.50 [521]	48 [1219]
10	BGSBS226020	20.50 [521]	60 [1524]
11	BGSBS226620	20.50 [521]	66 [1676]
12	BGSBS227820	20.50 [521]	78 [1981]
13	BGSBS228420	20.50 [521]	84 [2134]

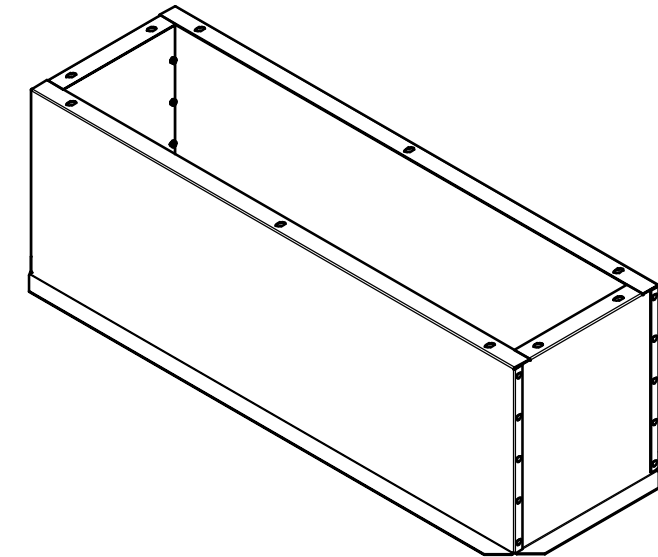
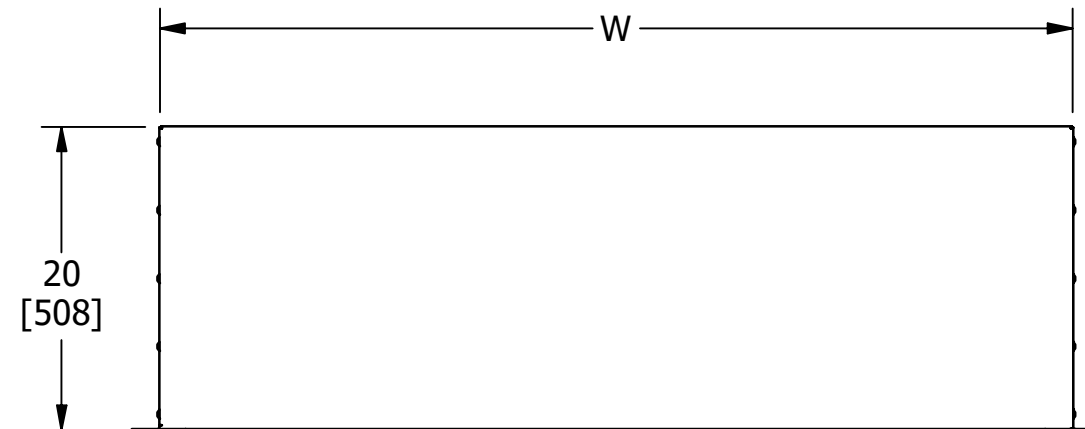
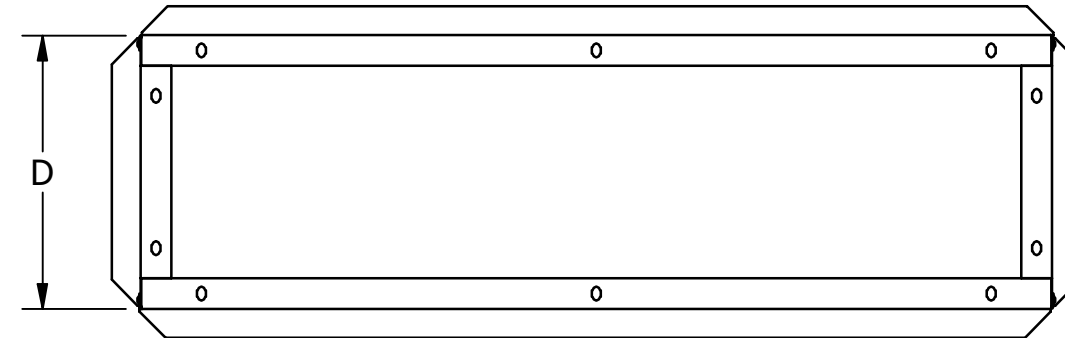
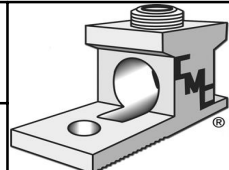

NOTES:

- ALL STEEL BURIAL SLEEVES ARE FABRICATED FROM 14-GAUGE GALVANNEALED STEEL AND HAVE AN OVEN CURED POWDER COAT POLYESTER FINISH.
- 304 STAINLESS STEEL CARRIAGE BOLTS SUPPLIED FOR ASSEMBLY

					TO ORDER CMC PRODUCTS	DRAWN BY: <b>TS</b> 04-20-20	NAME OF PART: <b>PRIMARY SECTIONALIZING ENCLOSURE BURIAL SLEEVE</b>	CAT. NO.: <b>SEE TABLE</b>
					UNITED STATES 1-513-860-4455	CHECKED BY:	DWG NO: <b>UB22700469-S (CHARTED)</b>	<b>A</b>
					CANADA 1-800-361-6975	<b>DRAWING NOT TO SCALE</b>		
					MEXICO 011-52-722-265-4400			
<b>A</b>	NEW DRAWING CREATED		04-20-20	TS	FOR PRODUCT INFO www.cmclugs.com			
REV.	DESCRIPTION	ECN	DATE	INIT.				